



# SOCIETY OF PHYSICS STUDENTS

An organization of the American Institute of Physics

## SPS Chapter Research Award Proposal

Project Proposal Title	Standardization of Novel Photovoltaic Cell Characterization for Rhodes College Cubesat Program, RHOK-SAT
Name of School	Rhodes College
SPS Chapter Number	5940
Total Amount Requested	\$2000.00

### Abstract

Rhodes College is leaving its footprint in space with a nanosatellite (a CubeSat), projected to be ready for launch in June of 2023. The payload's mission of the satellite is to characterize novel photovoltaic cells (PV) in low earth orbit. These cells, developed by the Photovoltaics Materials and Devices Group at the University of Oklahoma, show promise for providing remote power generation for future crewed and uncrewed space missions. To gather comparison data to which we can compare our future space experimental data, the RHOK-SAT team must perform terrestrial current-voltage measurements of the experimental PV cells. The Keithley 2400 Source Measurement Unit is a device widely renowned for its precise current-voltage characterization capabilities and would be instrumental in providing the necessary baseline data.

# Proposal Statement

## Overview of Proposed Project

RHOK-SAT is a 1U CubeSat with a mission conceived by a team of undergraduate students to test novel photovoltaic (PV) devices in low earth orbit. Through adequate financial support, ongoing collaborations, technical support and team participation throughout the pandemic, the Rhodes College CubeSat mission has manifested into a well detailed project with a projected launch date of June 2023. The financial support for the Rhodes CubeSat project comes from a generous alum (a recipient of the Sigma Pi Sigma Service Award) and covers the actual flight module, launch, and staff salary. It does not cover essential parts of the overall project, and that is the reason for our application for the SPS Chapter Research Award.

The scientific payload of RHOK-SAT is an experiment that will characterize novel PV cells to investigate their space hardiness. The two types of cells are; (1) state-of-the-art flexible copper indium gallium selenide cells with a silver absorption layer (ACIGS) and, (2) gallium arsenide antimonide (GaAsSb) cells. Both of these types of cells have not been tested in space and show promise for being great options for future space remote-power generation. While in orbit, the experiment will perform current-voltage sweeps simultaneously across all test cells. This data will be stored on the on board computer (OBC), until it is downlinked to our groundstation in Memphis, TN.

The RHOK-SAT research team proposes to collect standardized terrestrial data in the form of current-voltage (IV) sweeps on the ACIGS and GaAsSb cells we intend to fly on the Cubesat. In order to evaluate the cells' performance while in flight, our research team must have highly precise measurements as a baseline. Through comparison, we can evaluate the magnitude of the effect a harsh space environment has on solar cell performance. The Keithley 2400 Source Measurement Unit (SMU) is a precise 5-in-1 instrument that combines power supply, digital multimeter, current source, electronic load and pulse generating capabilities into one system. Widely regarded as the most reputable system for providing high accuracy data, this specific SMU is used by the Photovoltaics Materials and Devices Group at the University of Oklahoma, as well as those in the aerospace industry.

With student involvement from majors and interests across the spectrum, the RHOK-SAT project embodies SPS national's goal of increasing physics and science accessibility. As a small Liberal arts school taking on a highly technical aerospace engineering project, this research encourages communication skills and collaboration among undergraduates from all disciplines, faculty and industry contacts.

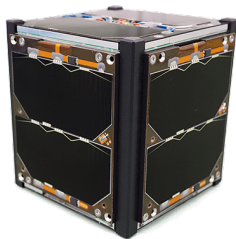

Figure [1]; A standard 1U Cubesat from Innovative Solutions in Space, our hardware provider.



Figure [2]; The Keithley 2400 SMU unit

## Background for Proposed Project

Cubesats are a subclass of nanosatellites that are becoming increasingly popular for space applications due to their relatively low production costs and overall versatility. In order to expand student interest in the vast science, technology, engineering and math (STEM) fields, Cubesats were created to challenge and inspire students to build skills for careers in space. The standard Cubesat design was developed by Dr. Jordi Puid-Suari of California Polytechnic State University and Bob Twigs of Stanford University in 1999 and serve to increase access to space for educational institutions like Rhodes College. Figure [1] depicts a standard Cubesat with a fixed volume of 10 x 10 x 10 cm, a single ‘cube’ “Unit” Or 1U.

When designing spacecraft, power generation is one of the most important considerations. According to NASA, “Solar power generation is the predominant method of power generation on small spacecraft” (Kovo). Even large spacecraft like the Hubble Space Telescope and the International Space Station rely on solar energy to keep their systems running, as seen by the large solar arrays in Figure [3]. However, a major limitation arising from reliance on solar cells are their tendency to degrade over the mission lifetime. Their efficiency decreases in space due to factors like thermal cycling and radiation stress. Therefore, research that strives to improve the efficiency and hardness of solar cells operating in a space environment is an important and essential.

Photovoltaic cells are a type of semiconductor diode which generate direct current from visible light. The photovoltaic effect was first discovered in 1839 by a French Scientist name Edmund Becquerel, when he discovered small quantities of electric current being produced when he exposed two metal diodes in an electricity-conducting solution to light. The first photovoltaic cell was based on silicon, a semiconductor that converts photons from sun light into electricity. Photovoltaic research and applications have far expanded beyond the typical silicon technologies, and now materials, like the types of cells we propose to test on RHOK-SAT, are becoming more and more prevalent.

ACIGS and GaAsSb PV cells show promise for increased power conversion efficiencies and greater radiation tolerances as compared to other solar technologies. ACIGS cells introduce silver into the absorbing layer of normal CIGS cells (Figure [4]), providing for a wider range of energy-producing wavelengths. In addition, the silver increases the annealing properties of normal CIGS cells, which means that in a space environment where temperatures regularly surpass 125 degrees Celsius, these cells could potentially heal themselves with time. Thin-film ACIGS PV cells have already proven successful for terrestrial applications and may be candidates for remote space power generation over silicon and perovskite-based cells, since they are more cost effective and have near-term readiness. In addition, the GaAsSb cells show promise to increase conversion efficiency by absorbing through the infrared part of the spectrum and their increased radiation-tolerance, compared to other widely used technologies. Notably, neither of these cells have been tested in low earth orbit. A schematic of the placement of the cells on RHOK-SAT is shown in Figure [5].

Solar cell current versus voltage (IV) curves are the typical method of characterizing a PV cell. Generally, the voltage is controlled to sweep over given range of values, and the corresponding response current is measured. Key performance data like maximum power and efficiency can be extracted through graphical analysis, providing insight into how well a particular test cell functions.

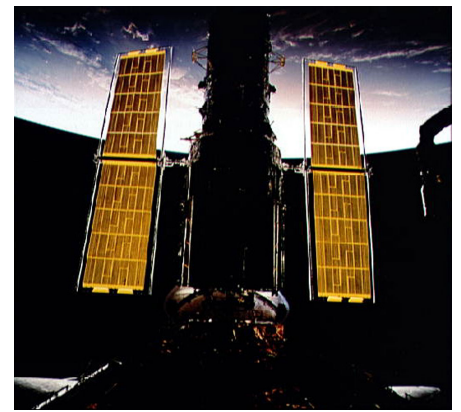

Figure [3]; The solar arrays on the Hubble Space Telescope

For terrestrial PV cell characterization, the Keithley 2400 Source Measurement Unit (SMU) is one of the most efficient and accurate systems to produce accredited data. Developed specifically for IV applications on a breadth of materials and devices, the SMU is used by photovoltaic research labs across academia and industry. Designed to test any type of diode, the SMU was created to streamline the IV testing process and minimize experimental error. The SMU provides solutions for solar cell IV characterization with accurate measurements in this 5 in 1 device without the hassles of integrating separate instruments or writing complicated programs.

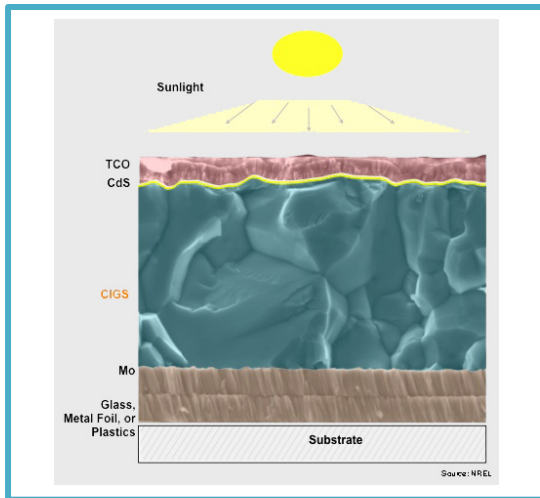

Figure [4]; A schematic of a typical CIGS cell. ACIGS incorporate silver into the absorbing layer.

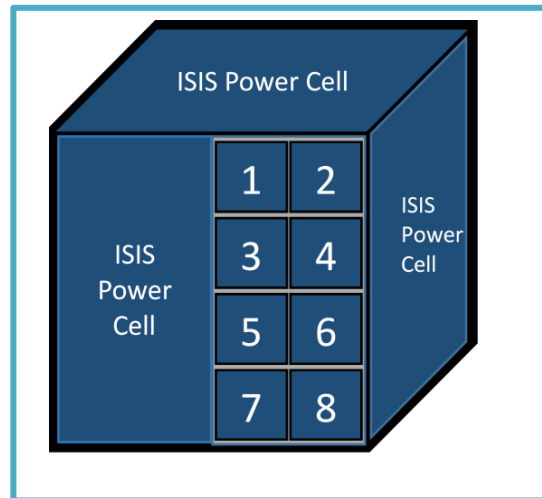

Figure [5]; A representation of RHOK-SAT design. cells 1-6 are going to be ACIGS, while cell 7 is a GaAsSb cell and 8 is a reference cell.

## Expected Results

IV characterization is a standard method to test the performance of solar cells. A graph showing a typical curve is shown in Figure [6]. From the output produced by the SMU, we are able to graphically deduce solar cell performance through the following performance factors; open circuit voltage, short circuit current density, maximum current, voltage, and power, fill factor and conversion efficiency.

Our performance parameters can be deduced from the graphical results.

- The short circuit current density,  $I_{sc}$ , is the current that exists without a voltage drop and no resistance, and entirely depends on the intensity of the light source. This parameter depends on factors of the cell like its absorption and reflection abilities. Often expressed in terms of area density, a typical industry silicon solar cell has an  $I_{sc}$  of 35 mA/cm<sup>2</sup>.

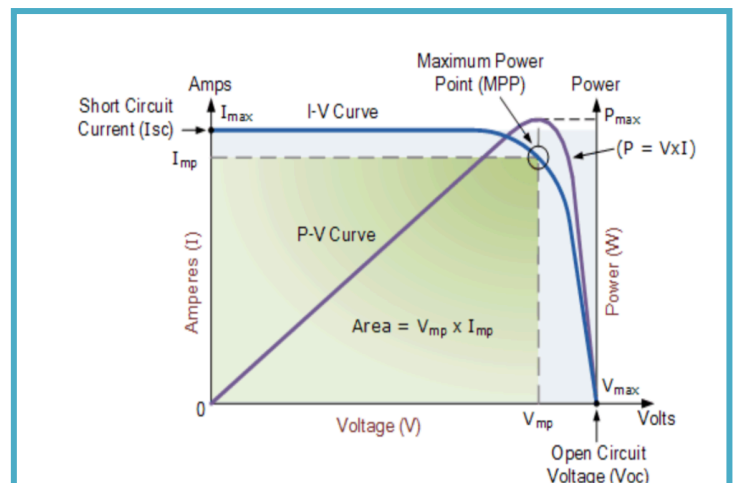

Figure [6]; An example of an IV curve we'd get from a given sweep, with the important parameters shown.

- Open circuit voltage,  $V_{oc}$ , is the voltage at which no current flows through the circuit, or the maximum voltage a cell is able to deliver. It is essentially a measure of the recombination of a cell, or the measure of the electrons stabilizing and lowering the energy.  $V_{oc}$  in the lab are on the order of 100's of mV for a cell.
- The fill factor is the ratio of maximum power to the open circuit voltage and short circuit current density. It is proportional to max voltage, so the greater the fill factor, the greater the voltage. The fill factor is approximately .75 for typical silicon cells.
- The conversion efficiency,  $\eta$ , is the ratio of the max power to incident power. It shows how much power the cell is able to produce.

## Description of Proposed Research - Methods, Design, and Procedures

### Methods

In order to test the efficiency of the novel photovoltaic cells in space, we plan to perform multiple tests in the laboratory to serve as baseline data. Tests will be performed with the Keithley 2400 Source Measurement Unit, which will perform the current/voltage sweep and output the corresponding graph.

### Design

The Keithley SMU greatly diminishes the test complexity and therefore opportunity for human error due to the fact it combines all the necessary equipment into one. For the IV characterization of the solar cells, the experimental design consists of the SMU unit, the solar cell, and the connecting cables. This is shown in Figure [7]. Without the Keithly SMU, the experimental set up would need to look like the schematic shown in Figure [8].

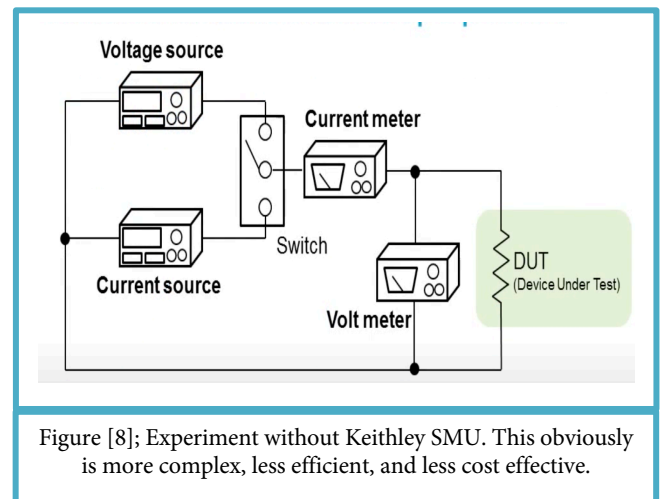
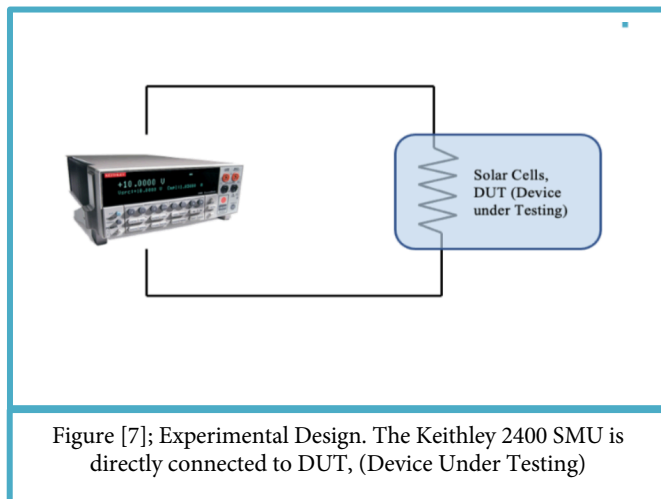

### Procedure

The Keithley 2400 will be programmed to perform a custom voltage sweep with the following parameters: Voltage range [-0.8 V => 1.2 V => -0.8V]; step size 10mV; dwell time 30ms; number of steps 400. Five current measurements will be made at each step for accuracy. The total test time will be 12 seconds/sweep.

Graphical results will be produced (see figure 6) to determine key characteristics ( $I_{max}$ ,  $P_{max}$ , etc). From these graphs, the following performance parameters will be extracted:

- Open circuit voltage ( $V_{oc}$ )
- Short circuit voltage ( $I_{sc}$ )
- Max Voltage and Current ( $V_{max}, I_{max}$ )
- Maximum power output ( $P_{max}$ )
- Conversion efficiency, ( $\eta$ )
- Fill Factor

## Plan for Carrying Out Proposed Project

The plan for the proposed project spans approximately two semesters. The test PV cells are currently available to ship and can be sent upon request from our collaborators at the University of Oklahoma. This proposed project will involve a number of SPS members, with oversight by physics department staff and faculty.

Lead students for the solar cell baseline characterizations are as follows:

- Giuliana Hofheins, a junior physics major. Giuliana is the student Co-Leader of RHOK-SAT, the co-founder of the Aerospace Engineering Club and its current Treasurer, and SPS Vice President. Involved in the CubeSat program from the start, she has worked in all fields of the project. As the “payload” sub-team leader, she has been especially working on the solar cell aspect.
- Ben Wilson, a junior physics major. Ben is also the student Co-Leader of RHOK-SAT and the co-founder and current President of the Aerospace Engineering Club. Ben’s summer research on the project has provided experience in solar cell characterization using the Arduino microcontroller.
- Olivia Kaufmann, a sophomore physics major. Olivia is the current SPS On Campus Programmer, responsible for organizing Aerospace panels comprised of Rhodes Alumni for the physics department. Olivia in the spring of 2020 worked on characterizing piezoelectric PVDF sensors for a separate payload idea.
- Other SPS Members that will be working on this research include Jo Boff (Neuroscience ’22), Raeba Ann Roy (Computer Science ’22) (two other contributors to this proposal), Eli Matlock (Physics ’21), Finn Giddings, (Physics ’22), Dasha Safarian (Chemistry ’21), and Jess Hamer (Physics ’23) as well as any others that show interest.
- Joe McPherson, Physics Technical Associate and the CubeSat Project Manager. Joe has worked with the University of Oklahoma and Aerospace Corporation to understand the communications between the cells and the satellite. Joe was a main contributor of RHOK-SAT’s project proposal for NASA’s CubeSat Launch Initiative.
- Dr. Ann Viano, Sigma Pi Sigma (SPS) chapter advisor and Physics faculty member. Dr. Viano is currently working with the AMU and solar cells and is the current Electronics course professor. She is also a main contributor of RHOK-SAT’s project proposal for NASA’s CubeSat Launch Initiative.
- Dr. Brent Hoffmeister, SPS chapter advisor, Physics faculty member and a main contributor of RHOK-SAT’s project proposal for NASA’s CubeSat Launch Initiative.

The activities of the proposed project will be conducted at Rhodes College. The Physics Department has a space dedicated to student projects which has laboratory furniture, computers, electrical supplies, and all other necessary resources for the proposed project. The CubeSat communications room is located on the fourth floor of the Physics building, in the engineering room. The same space will function for solar cell characterization research.



## Project Timeline

	January '21	February	March	April	May	June	July	August	September	October	November	December
	School Year	-----	-----	-----	Summer Work	-----	-----	-----	School Year	-----	-----	-----
Order/Ship time Literature Review												
Familiarization and preliminary testing												
University of Oklahoma cell testing												
Conclusions												

### January 2021:

We will order the Keithley machine and conduct a literature review so we can work to better understand what we are measuring,

### February 2021:

Assuming a lead time of no more than a month, we will receive the machine and students begin to familiarize themselves with the machine and its functions. Our team will continue research into solar cell information and what data we need to collect in order to have accurate and credible baseline measurements.

### March 2021:

We will begin to work on preliminary testing, using cheaper solar cells which have already been purchased for members of the team.

### April 2021:

We plan to continue conducting testing with solar cells, begin analyzing and characterizing the data we have collected and use this data to complete the interim report.

May 2021: --INTERIM REPORT--

### June 2021:

Summer research will begin - We will begin testing solar cells provided by the University of Oklahoma to get our baseline measurements.

### July 2021:

We will continue testing cells and begin analyzing and processing the data we have produced.

### August 2021:

End of Summer research- We will finalize the testing being done with the ACIGS and GaAsSb cells. We will begin generating some conclusions and finish analyzing our data. We will also compare the measurements we get to those that the University of Oklahoma gives us, so we can ensure the cells are ready to be space tested.

### September 2021:

We will likely continue the work that is started in August into September and bring people who did not participate in research over the summer up to speed on the conclusions we have drawn and the research we conducted.

October 2021:

At this point in time we will begin working on our final research report and creating a formal conclusion with our data.

November 2021: --FINAL REPORT--

## Budget Justification

Our proposed satellite payload experiment, developed by the University of Oklahoma's Photovoltaic Materials and Devices Group, will help characterize new kinds of solar cells to be used in space applications. In order to deliver accurate and credible results about the cells' performance in space, we need to have a good standard measurement to compare the space test results. While in orbit the cells will be tested through a specialized microchip. To conduct testing on the ground we need to purchase a Keithley 2400 Source Measurement Unit from Tektronix.

The particular model we are looking to purchase costs \$5,770 so we will acquire supplemental funding beyond this award. The Rhodes Aerospace Engineering Club will submit a request to the Rhodes Allocations Board for approximately \$2000, as the proposed project also supports the activities of the newly formed Club. The Rhodes Physics Department should be able to cover the remaining expenses associated with this purchase.



## Bibliography

- Alternative Energy Tutorials. "Solar Cell I-V Characteristic." *Alternative Energy Tutorials*, Alternative Energy Tutorials, 8 Feb. 2020, [www.alternative-energy-tutorials.com/energy-articles/solar-cell-i-v-characteristic.html](http://www.alternative-energy-tutorials.com/energy-articles/solar-cell-i-v-characteristic.html).
- Howell, Elizabeth. "CubeSats: Tiny Payloads, Huge Benefits for Space Research." *Space.com*, Space.com, 19 June 2018, [www.space.com/34324-cubesats.html](http://www.space.com/34324-cubesats.html).
- Keithley Systems, Tetronix. "I-V Characterization of Photovoltaic Cells Using the Model 2450 SourceMeter® Source Measure Unit (SMU) Instrument." *Tetronix*, Tetronix, 2013, [www.mouser.com/pdfdocs/Photovoltaic2450SMU\\_AN1.PDF](http://www.mouser.com/pdfdocs/Photovoltaic2450SMU_AN1.PDF).
- Knier, Gil. "How Do Photovoltaics Work?" *NASA*, NASA, 6 Aug. 2008, [science.nasa.gov/science-news/science-at-nasa/2002/solarcells](http://science.nasa.gov/science-news/science-at-nasa/2002/solarcells).
- Kovo, Yael. "Power." *NASA*, NASA, 12 Mar. 2020, [www.nasa.gov/smallsat-institute/sst-soa/power](http://www.nasa.gov/smallsat-institute/sst-soa/power).
- Mungale, Aishwarya. "Solar Cell Efficiency- Solar Cell I-V Characteristic Curves: ScienceMonk." *Everything In Science- Physics, Chemistry, Biology and Space*, ScienceMonk, 20 Oct. 2020, [sciencemonk.com/solar-cell-efficiency/](http://sciencemonk.com/solar-cell-efficiency/).
- Press Office. "U.S. Department of Education Launches Space Mission Challenge for High School Students." *U.S. Department of Education*, U.S. Department of Education, 18 Aug. 2020, [www.ed.gov/news/press-releases/us-department-education-launches-space-mission-challenge-high-school-students](http://www.ed.gov/news/press-releases/us-department-education-launches-space-mission-challenge-high-school-students).