



# SOCIETY OF PHYSICS STUDENTS

An organization of the American Institute of Physics

## Marsh W. White Award Proposal

---

Project Proposal Title	TechFest 2019: Electro-Physics Exhibit
Name of School	University of Dayton
SPS Chapter Number	1500
Total Amount Requested	[\$440.00]

### Abstract

University of Dayton's SPS chapter is participating in TechFest 2019 in Dayton, Ohio. This unique, family-focused STEM event gives children opportunities for learning and excitement about STEM, matching a core goal of our chapter. Our exhibit's focus is Electromagnetism and Electrostatics, using maglev trains and electrostatically moving water molecules.

# Proposal Statement

## **Project Description:**

Our Chapter is participating in TechFest 2019 in Dayton, Ohio as an exhibitor and proponent of physics engagement. This is a two day event lasting about 6 hours each day where we engage and excite children and families that attend. The UD chapter of SPS has been an exhibitor at TechFest every year for the past decade, but this year we are looking to expand our footprint by developing two larger, interactive exhibits centered around teaching fundamental Electrostatic and Electromagnetic phenomena. For the Electrostatic exhibit we will be starting attendees with levitating and attracting mylar and then give them the opportunity to bend running streams of water. For the Electromagnetism, we start attendees with teaching polarity of magnets and demonstrating the magnetic field with iron filings. We then give them the opportunity to put together their own maglev train to test on a portable maglev track. If time and attention permit we will then teach momentum using the maglev track and trains.

## **Goals of the Project:**

As an SPS chapter at a STEM-focused event for children and their families, our goals are:

- To give children memorable and useful experiences around fundamental physical phenomena.
- To teach simple and complex lessons in Electromagnetism and Electrostatics using our proposed exhibits.
- To instill a desire to pursue STEM careers and hobbies in all participants attending, especially in physics.

## **Intended Audience:**

TechFest 2018 had an attendance of 2285 registered students, with ages ranging from elementary to middle school. In addition, parents, other adults, and non-registered students attended, with a total estimated attendance of 4000. We expect similar numbers this year and will tailor our exhibit to all students within these age groups.

## **Project Background:**

Our chapter has been participating in TechFest for several years to much success, including a vacuum chamber marshmallow exhibit, gravity well, non-newtonian fluids, a chaos math pendulum, density experiments, a friction book tug-of-war, and many others. There are many reasons we have participated in TechFest. First and foremost, physics outreach is written in our chapter's constitution and we take that role quite seriously. In addition, TechFest is already organized by the Dayton community, having great marketing and a strong following. This lets our chapter focus on creating great activities and experiences, rather than focusing on trivial details.

As for our project ideas, we have, in previous years, done many kinematic-based exhibits and activities, and wanted to work with more abstract phenomena (at least for children), and decided that Electromagnetics would be a good choice. This is especially true with the continued electrification of transport happening over the next decade. As for Electrostatics, we have an SPS member who is highly interested in use cases for electrostatics, and wanted to share with future STEM students that excitement and interest. In our chapter, we have multiple electrical engineering senior undergraduates, as well as multiple senior physics majors who have strong backgrounds in the fundamentals of electromagnetics and Electrostatics, allowing our chapter to execute our exhibits well, but also to teach abstract concepts to even the youngest children in attendance.

## **Promotion of Physics:**

TechFest is the largest STEM focused event for students and the general public in the Greater Dayton Area, and has been a source of inspiration for many students who attend to enter STEM fields and careers since its inception. In past years, our chapter has been highlighted by attendees as having some of the best learning opportunities and engagement for students of all ages. All of our exhibits focus on fundamental physics and we take time to plan out what we want to teach students with each and every exhibit, and how we can encourage them to take an interest in physics.



## **Execution Plan:**

### **Personnel and Leadership:**

For TechFest, our chapter typically has about 15-20 volunteers, including our event chair and executive team. These members are responsible for designing and building our exhibits as well as designing our teaching points and goals for students who visit our exhibit. Beyond SPS members, the University of Dayton Physics Department will often provide input and feedback as needed for our designs and ideas. It is our SPS chapter advisor, Dr. Jay Mathews and our leadership team that ensures that we are prepared for TechFest each year in advance, and help as needed to keep the project on track.

### **Marketing:**

As TechFest is hosted by the Affiliate Societies Council in Dayton, they take care of logistics, marketing, school outreach, and other important details, leaving exhibitors like us to focus on creating engaging exhibits and experiences. This does not mean we do not have to make an effort for marketing. Because TechFest is such a large event, we have a lot of competition in terms of other great exhibits requiring us to take time to design attractive banners and attractive designs for our individual exhibits, as well as ensure our chapter members are engaging as possible. This year, to accomplish these goals, we will ensure all new SPS members are given a time slot over the two days to work with an experienced member to learn how to be as engaging as possible, and we will leverage one of our member's artistic talents with fractals and a local makerspace to create engaging banners and wraps for our projects.

### **Execution/Expertise:**

As said earlier, our chapter has multiple senior physics majors who have strong backgrounds in the fundamentals of electromagnetics and electrostatics, as well as multiple electrical engineering senior undergraduates, allowing our chapter to execute our exhibits well, but also to teach abstract concepts to even the youngest children in attendance. More specifically, every underlying experiment to be used in our exhibits has been conducted by at least one of our members prior to this project. This includes the fun-fly sticks and Mylar static experiment, the maglev train with 2x4's of wood, 1D momentum experiments using levitating objects, the sump-pump system and water bending using static, the iron-filings and magnetic fields experiment, and the glass-wool initial static demonstration using an electroscope.

We have designated SPS chapter space on campus for building and storage of these exhibits, as well as makerspace access for the woodwork and construction. There is also an inexpensive large format printer we will be using to print the marketing banners and wraps for this project. Each member that has previous experience with the experiments will be leading the build process for those exhibits and be tasked with ensuring success of that project.

## **Proposed Timeline:**

November 15, 2018:	Run a funding bake sale as a Chapter to supplement funding from Marsh W. White award
End November, 2018:	Finalize design of marketing materials, the exhibits, and the underlying lessons being taught.
End November, 2018:	Collect what parts we can from members and the University, including an Electroscope, demonstration static materials, etc.
Early January, 2019:	Purchase of material for building exhibits
Late January, 2019:	Construction and testing of designs Buying and applying marketing wraps for the exhibits Receive first disbursement from Marsh W. White Award
Early February:	Final review by leadership team
<b>Saturday Feb. 16<sup>th</sup></b>	
<b>10AM-6PM:</b>	TechFest, 2019 Day 1
<b>Sunday Feb. 17<sup>th</sup></b>	

## Activity Evaluation Plan

The easiest/most effective way that we will evaluate our success at TechFest 2019 is to keep track of how many students and parents visit our exhibit using simple mechanical counters. We will then speak with the parents that attend our station and ask them how we are doing via either an informal question and answer process, or a more formal written survey. The proposed questions we will be asking are as follows:

1. How engaged do you think your child/student was/is interacting with our exhibit compared to others you have visited? (Least Engaged) 1 2 3 4 5 (Most Engaged)
  
2. Did you find our members engaging and did they provide approachable explanations and lessons?  
No Yes Why: \_\_\_\_\_
  
3. Did you learn something new about Physics today?  
No Yes, I learned \_\_\_\_\_

Beyond asking attendees, we will also informally receive feedback from other exhibitors, which is quite commonly given during TechFest. Members of the Physics Department including the department chair will also likely attend at some point during the event and provide feedback.

## Budget Justification

Our exhibit is broken into two tracks: electromagnetism and electrostatics. Each section has a description and the items corresponding to budget lines (BL#'s) in the budget. Items from in-kind support listed in budget.

### Electromagnetic Exhibit:

#### Part 1: Intro to Magnets with Poles

This experiment teaches students the basics of north/south poles of magnets:

BL-1: Assorted Magnet Set

#### Part 2: Magnetic Fields and Electromagnets

This experiment teaches magnetic fields through iron filling visualization and electromagnetism through a hand-crank Electromagnetic generator and electromagnet:

BL-2: Iron Filling Display

BL-3: Electromagnet

BL-4: Hand-Crank Generator

#### Part 3: Assemble Maglev Train and (possibly) Learn 1D momentum

This experiment allows students to test their skills by letting them place magnets in the maglev train to make it levitate, 1D momentum will be explained, time permitting:

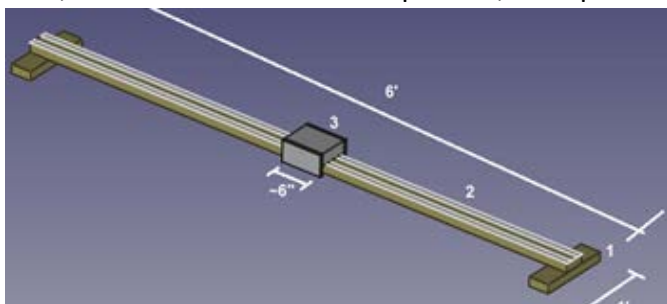

BL-5: 2x4's frame (labeled "1")

BL-6: 8' magnetic strips (labeled "2")

BL-5: 2x4 trains (2-3) (labeled "3")

BL-7: Wood screws

BL-8: Wood Glue

BL-9: Marketing Wrap for trains and wood

Figure 1: Maglev Design

### Electrostatic Exhibit:

#### Part 1: Intro to Static and Electroscopes

Using glass, wool, Etc. demonstrations of electrostatic force and dissipation using an electroscope:

BL-9: Various Materials

BL-10: Electroscope for demonstration

#### Part 2: Fun-Fly-Sticks and Mylar

These static wands are simple van de graaff generators creating harmless voltages used to attract and levitate Mylar figures:

BL-11: 4 Fun Fly Sticks (4 because some will be broken by users)

#### Part 3: Bending Water with Static Electricity

Users test polarity of water molecules using water-proofed Fun-Fly-Sticks

BL-5: 2x4 wood frame, 2'x3' base by 4' tall (Labeled '6')

BL-12: 3'x2' Water tub

(Labeled '1')

BL-13: Water pump

(Labeled '2')

BL-14&15: Water Tubing and Clamps

(Labeled '5')

BL-16: Containment Plexiglass

(Labeled '3')

BL-17: Top Plywood

(Labeled '4')

BL-18: Marketing wraps

(Not labeled)

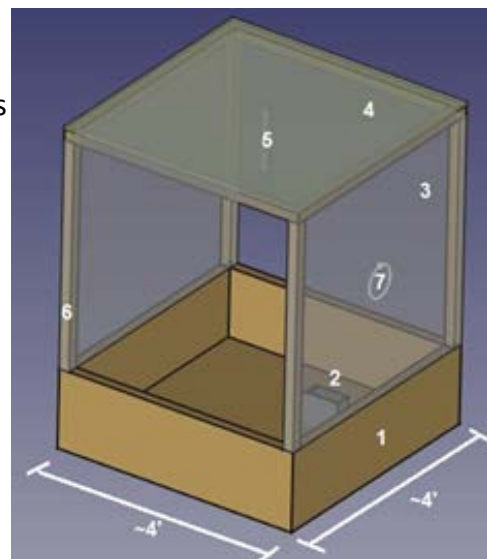

Figure 2: Static-Water Design